

GMAW

CONTEST NUMBER 1003

GUSSET		
1	VERTICAL UP	3 /5
	VERTICAL DOWN	4 /5
2	VERTICAL UP	2.5 /5
	VERTICAL DOWN	4 /5
3	VERTICAL UP	3 /5
	VERTICAL DOWN	4 /5
4	VERTICAL UP	3 /5
	VERTICAL DOWN	4 /5
SIDE		27.5
A	VERTICAL UP	5.5 /10
B	VERTICAL DOWN	8 /10
C	VERTICAL UP	6 /10
D	VERTICAL DOWN	6 /10
PAC		25.5
E	PLASMA CUT	6.5 /10
ALL AROUND		
F	BASEPLATE WELD	6.5 /10
LAYOUT PENALTY		5
		61 /100 PTS

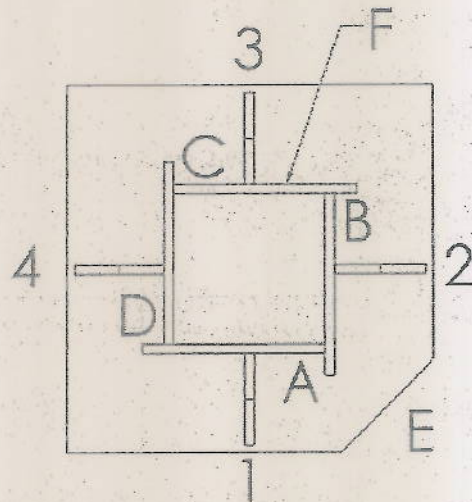

Welds are small +
 layout is a bit
 off + tilted,
 but nice consistency
 on your vert-downs!

GMAW

CONTEST NUMBER 1004

Turn your gas on

GUSSET			
1	VERTICAL UP	1	/5
	VERTICAL DOWN	1	/5
2	VERTICAL UP	1	/5
	VERTICAL DOWN	1	/5
3	VERTICAL UP	1	/5
	VERTICAL DOWN	1	/5
4	VERTICAL UP	1	/5
	VERTICAL DOWN	1	/5
SIDE			
A	VERTICAL UP	1	/10
B	VERTICAL DOWN	0	/10
C	VERTICAL UP	1	/10
D	VERTICAL DOWN	1	/10
PAC			
E	PLASMA CUT	6	/10
ALL AROUND			
F	BASEPLATE WELD	1	/10
LAYOUT PENALTY		10	
8		/100 PTS	

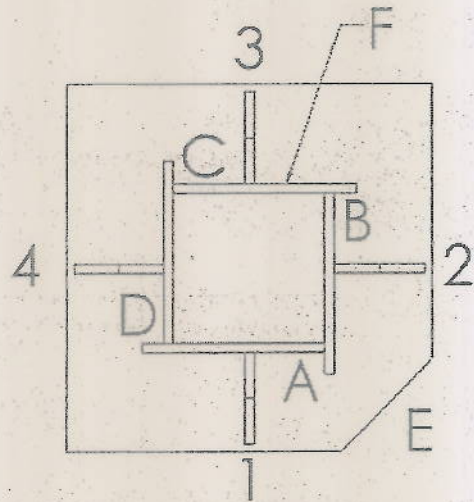

*layout & plasma cut
not too bad!
missing alot of welds
& consistency.*

A

GMAW

CONTEST NUMBER 1031

GUSSET			
1	VERTICAL UP	4	/5
	VERTICAL DOWN	4	/5
2	VERTICAL UP	4	/5
	VERTICAL DOWN	4	/5
3	VERTICAL UP	4	/5
	VERTICAL DOWN	4	/5
4	VERTICAL UP	4	/5
	VERTICAL DOWN	4	/5
SIDE		32	
A	VERTICAL UP	6.5	/10
B	VERTICAL DOWN	7.5	/10
C	VERTICAL UP	7	/10
D	VERTICAL DOWN	7.5	/10
PAC		28.5	
E	PLASMA CUT	7	/10
ALL AROUND			
F	BASEPLATE WELD	6.5	/10
LAYOUT PENALTY		-	
		74	/100 PTS

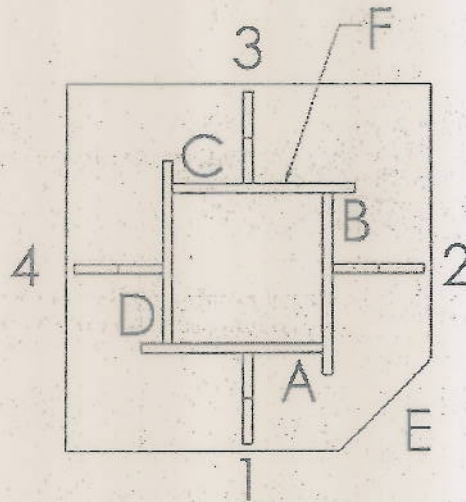

*Watch your spatter,
but overall, nice
consistency;*

P/

GMAW

CONTEST NUMBER 1023

GUSSET		
1	VERTICAL UP	4.5 /5
	VERTICAL DOWN	5 /5
2	VERTICAL UP	4.5 /5
	VERTICAL DOWN	4.5 /5
3	VERTICAL UP	4.5 /5
	VERTICAL DOWN	5 /5
4	VERTICAL UP	4.5 /5
	VERTICAL DOWN	5 /5
SIDE		37.5
A	VERTICAL UP	8 /10
B	VERTICAL DOWN	8 /10
C	VERTICAL UP	8 /10
D	VERTICAL DOWN	8.5 /10
PAC		32.5
E	PLASMA CUT	8 /10
ALL AROUND		
F	BASEPLATE WELD	9.5 /10
LAYOUT PENALTY		-
87.5		/100 PTS

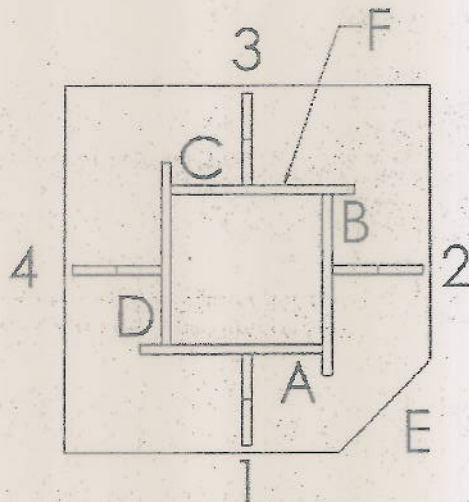

Welds very consistent!
Great job!

ORR

A

A

GMAW

CONTEST NUMBER 1024

GUSSET			
1	VERTICAL UP	5	/5
	VERTICAL DOWN	5	/5
2	VERTICAL UP	4.5	/5
	VERTICAL DOWN	5	/5
3	VERTICAL UP	4.5	/5
	VERTICAL DOWN	5	/5
4	VERTICAL UP	4.5	/5
	VERTICAL DOWN	5	/5
SIDE			
A	VERTICAL UP	9.5	/10
B	VERTICAL DOWN	10	/10
C	VERTICAL UP	9.5	/10
D	VERTICAL DOWN	10	/10
PAC			
E	PLASMA CUT	9	/10
ALL AROUND			
F	BASEPLATE WELD	9	/10
LAYOUT PENALTY			-
		95.5	/100 PTS

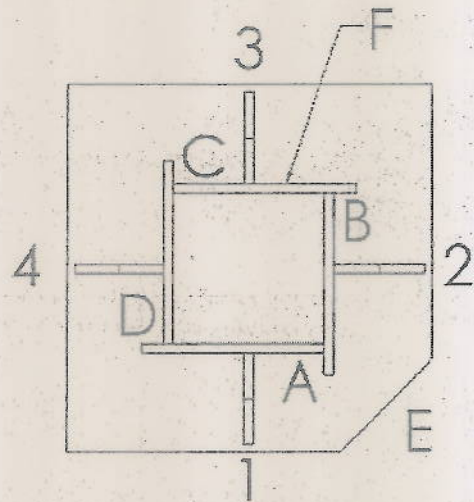

Very nice welds! Very consistent! Great job!

A

P✓

GMAW

CONTEST NUMBER 1032

GUSSET		
1	VERTICAL UP	2 /5
	VERTICAL DOWN	2.5 /5
2	VERTICAL UP	2 /5
	VERTICAL DOWN	3 /5
3	VERTICAL UP	2.5 /5
	VERTICAL DOWN	2.5 /5
4	VERTICAL UP	2 /5
	VERTICAL DOWN	2 /5
SIDE		18.5
A	VERTICAL UP	4 /10
B	VERTICAL DOWN	6.5 /10
C	VERTICAL UP	4 /10
D	VERTICAL DOWN	6.5 /10
PAC		
E	PLASMA CUT	6 /10
ALL AROUND		
F	BASEPLATE WELD	7 /10
LAYOUT PENALTY		5
47.5		/100 PTS

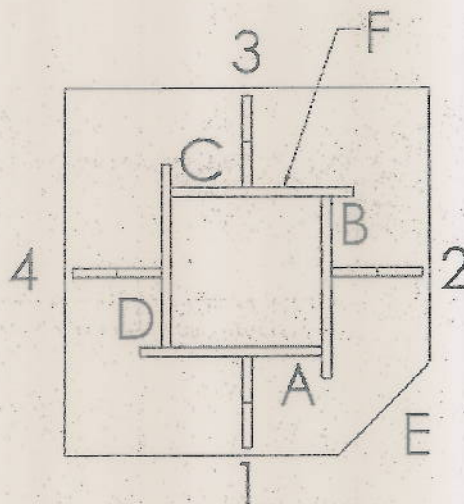

21
13 there are some really nice welds on the base plate!

P✓

GMAW

CONTEST NUMBER 1040

GUSSET			
1	VERTICAL UP	2.5	/5
	VERTICAL DOWN	3	/5
2	VERTICAL UP	2.5	/5
	VERTICAL DOWN	3	/5
3	VERTICAL UP	2.5	/5
	VERTICAL DOWN	3	/5
4	VERTICAL UP	2.5	/5
	VERTICAL DOWN	3	/5
SIDE			
A	VERTICAL UP	5	/10
B	VERTICAL DOWN	5	/10
C	VERTICAL UP	5	/10
D	VERTICAL DOWN	5	/10
PAC			
E	PLASMA CUT	0	/10
ALL AROUND			
F	BASEPLATE WELD	5.5	/10
LAYOUT PENALTY		5	
		42.5	/100 PTS

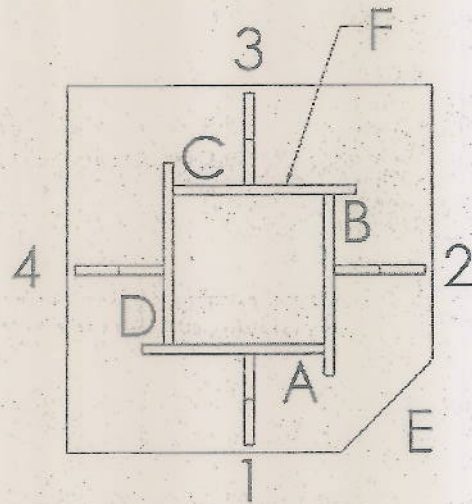

Overall layout is not to print, no plasma cut welds lack consistency.

GMAW

CONTEST NUMBER 1042

GUSSET		
1	VERTICAL UP	5 /5
	VERTICAL DOWN	5 /5
2	VERTICAL UP	5 /5
	VERTICAL DOWN	5 /5
3	VERTICAL UP	5 /5
	VERTICAL DOWN	5 /5
4	VERTICAL UP	5 /5
	VERTICAL DOWN	5 /5
SIDE		
A	VERTICAL UP	8 /10
B	VERTICAL DOWN	7 /10
C	VERTICAL UP	8 /10
D	VERTICAL DOWN	7.5 /10
PAC		
E	PLASMA CUT	8 /10
ALL AROUND		
F	BASEPLATE WELD	8.5 /10
LAYOUT PENALTY		0.5 -
		86.5 /100 PTS

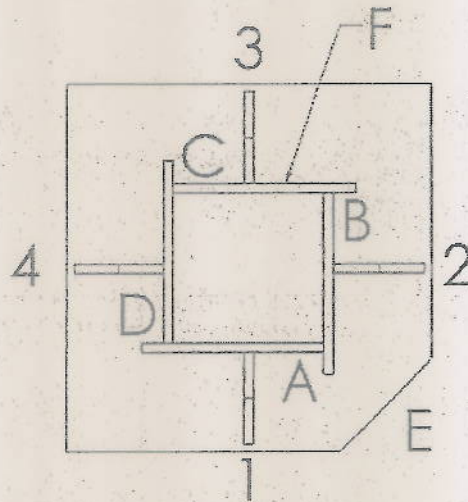

layout slightly off in some places, but overall good job!

A✓

GMAW

CONTEST NUMBER 10418

GUSSET		
1	VERTICAL UP	4.5 /5
	VERTICAL DOWN	4.5 /5
2	VERTICAL UP	4.5 /5
	VERTICAL DOWN	4.5 /5
3	VERTICAL UP	4.5 /5
	VERTICAL DOWN	4.5 /5
4	VERTICAL UP	4.5 /5
	VERTICAL DOWN	4.5 /5
SIDE		
A	VERTICAL UP	7.5 /10
B	VERTICAL DOWN	8 /10
C	VERTICAL UP	7.5 /10
D	VERTICAL DOWN	8 /10
PAC		
E	PLASMA CUT	8.5 /10
ALL AROUND		
F	BASEPLATE WELD	8.5 /10
LAYOUT PENALTY		-
84		/100 PTS

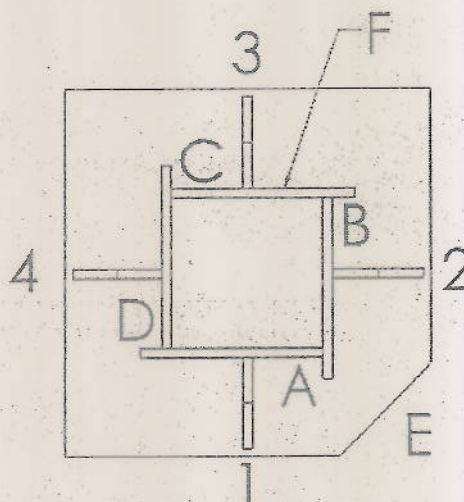

Consistent welds.
Vert - ups looked good.

✓

GMAW

CONTEST NUMBER 1065

GUSSET		
1	VERTICAL UP	3 /5
	VERTICAL DOWN	3.5 /5
2	VERTICAL UP	3.5 /5
	VERTICAL DOWN	3.5 /5
3	VERTICAL UP	3.5 /5
	VERTICAL DOWN	3.5 /5
4	VERTICAL UP	3.5 /5
	VERTICAL DOWN	3.5 /5
SIDE		27.5
A	VERTICAL UP	7 /10
B	VERTICAL DOWN	6.5 /10
C	VERTICAL UP	7.5 /10
D	VERTICAL DOWN	7 /10
PAC		28
E	PLASMA CUT	7.5 /10
ALL AROUND		
F	BASEPLATE WELD	7 /10
LAYOUT PENALTY		1
69		/100 PTS

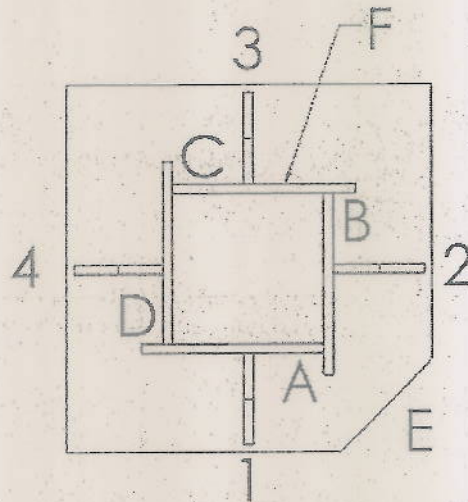

Overall, nice consistency,
 watch your weave size
 on your vert-downs,
 but good job!

P

GMAW

CONTEST NUMBER 1066

GUSSET		
1	VERTICAL UP	3.5 /5
	VERTICAL DOWN	4.5 /5
2	VERTICAL UP	4 /5
	VERTICAL DOWN	4.5 /5
3	VERTICAL UP	4.5 /5
	VERTICAL DOWN	4.5 /5
4	VERTICAL UP	4 /5
	VERTICAL DOWN	4.5 /5
SIDE		34
A	VERTICAL UP	7.5 /10
B	VERTICAL DOWN	8.5 /10
C	VERTICAL UP	7 /10
D	VERTICAL DOWN	8.5 /10
PAC		
E	PLASMA CUT	7.5 /10
ALL AROUND		
F	BASEPLATE WELD	8.5 /10
LAYOUT PENALTY		5
		76.5 /100 PTS

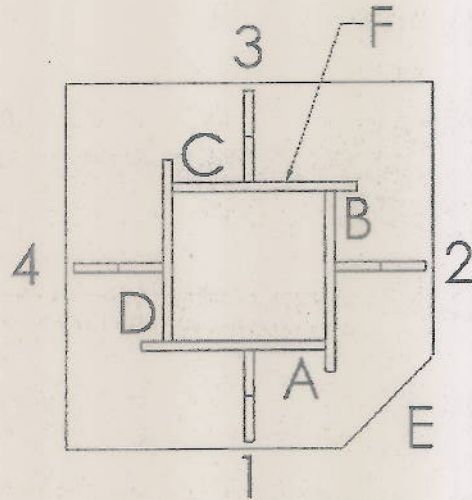

*layout is off,
but really nice weld
consistency!
great job!*

P

GMAW

CONTEST NUMBER 1087

GUSSET		
1	VERTICAL UP	2.5 /5
	VERTICAL DOWN	4 /5
2	VERTICAL UP	2.5 /5
	VERTICAL DOWN	5 /5
3	VERTICAL UP	3 /5
	VERTICAL DOWN	6 /5
4	VERTICAL UP	3 /5
	VERTICAL DOWN	5 /5
SIDE		30
A	VERTICAL UP	6 /10
B	VERTICAL DOWN	7 /10
C	VERTICAL UP	6 /10
D	VERTICAL DOWN	7 /10
PAC		
E	PLASMA CUT	9 /10
ALL AROUND		
F	BASEPLATE WELD	8.5 /10
LAYOUT PENALTY		5 -
68.5		/100 PTS

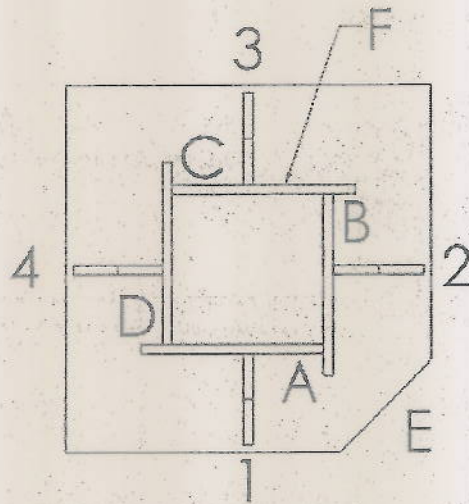

Nice Vert-downs - watch
your gas though
overall, good job

73.5

P

GMAW

CONTEST NUMBER 1089

GUSSET		
1	VERTICAL UP	3 /5
	VERTICAL DOWN	3.5 /5
2	VERTICAL UP	3 /5
	VERTICAL DOWN	3.5 /5
3	VERTICAL UP	3 /5
	VERTICAL DOWN	3.5 /5
4	VERTICAL UP	3 /5
	VERTICAL DOWN	3.5 /5
SIDE		26
A	VERTICAL UP	3.5 /10
B	VERTICAL DOWN	3.5 /10
C	VERTICAL UP	3.5 /10
D	VERTICAL DOWN	6 /10
PAC		
E	PLASMA CUT	5 /10
ALL AROUND		
F	BASEPLATE WELD	0 /10
LAYOUT PENALTY		5
42.5		/100 PTS

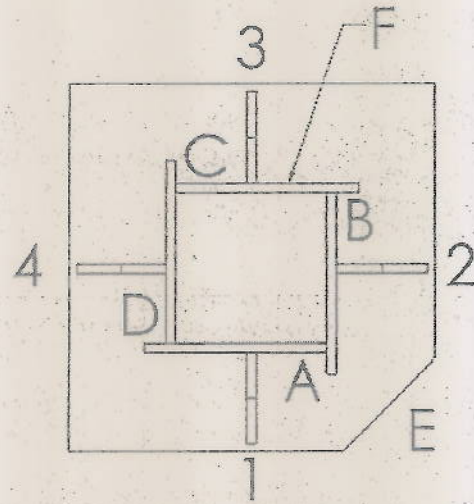

16.5
 5
 47.5
 - 5
 42.5
 MK1

layout is quite off,
 nice attempt

P

GMAW

CONTEST NUMBER 1095

GUSSET		
1	VERTICAL UP	4.5 /5
	VERTICAL DOWN	4.5 /5
2	VERTICAL UP	4.5 /5
	VERTICAL DOWN	4.5 /5
3	VERTICAL UP	4.5 /5
	VERTICAL DOWN	4.5 /5
4	VERTICAL UP	4.5 /5
	VERTICAL DOWN	4.5 /5
SIDE		
A	VERTICAL UP	8 /10
B	VERTICAL DOWN	7.5 /10
C	VERTICAL UP	8 /10
D	VERTICAL DOWN	7.5 /10
PAC		
E	PLASMA CUT	10 /10
ALL AROUND		
F	BASEPLATE WELD	7.5 /10
LAYOUT PENALTY		-
84.5		/100 PTS

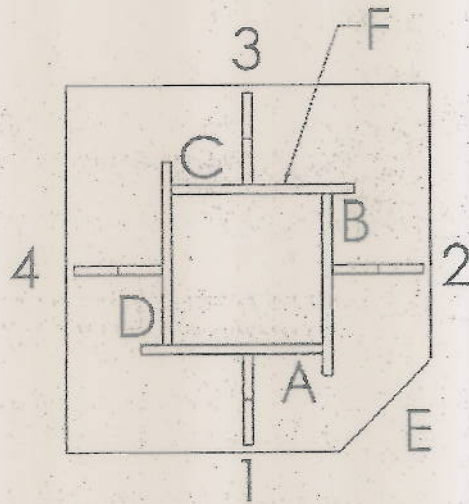

great Plasma cut!
 Downhill welds are a little shakey, but overall great job!

A

GMAW

CONTEST NUMBER 1097

GUSSET		
1	VERTICAL UP	3 /5
	VERTICAL DOWN	3.5 /5
2	VERTICAL UP	3 /5
	VERTICAL DOWN	3.5 /5
3	VERTICAL UP	3 /5
	VERTICAL DOWN	3.5 /5
4	VERTICAL UP	3 /5
	VERTICAL DOWN	3.5 /5
SIDE		
A	VERTICAL UP	6.5 /10
B	VERTICAL DOWN	8 /10
C	VERTICAL UP	7 /10
D	VERTICAL DOWN	7.5 /10
PAC		
E	PLASMA CUT	8 /10
ALL AROUND		
F	BASEPLATE WELD	6 /10
LAYOUT PENALTY		5
64		/100 PTS

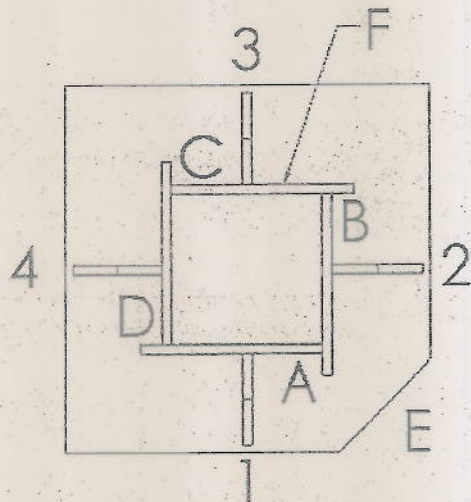

layout is off

A

GMAW

CONTEST NUMBER

1098

GUSSET		
1	VERTICAL UP	/5
	VERTICAL DOWN	/5
2	VERTICAL UP	/5
	VERTICAL DOWN	/5
3	VERTICAL UP	/5
	VERTICAL DOWN	/5
4	VERTICAL UP	/5
	VERTICAL DOWN	/5
SIDE		
A	VERTICAL UP	/10
B	VERTICAL DOWN	/10
C	VERTICAL UP	/10
D	VERTICAL DOWN	/10
PAC		
E	PLASMA CUT	/10
ALL AROUND		
F	BASEPLATE WELD	/10
LAYOUT PENALTY		-
0		/100 PTS

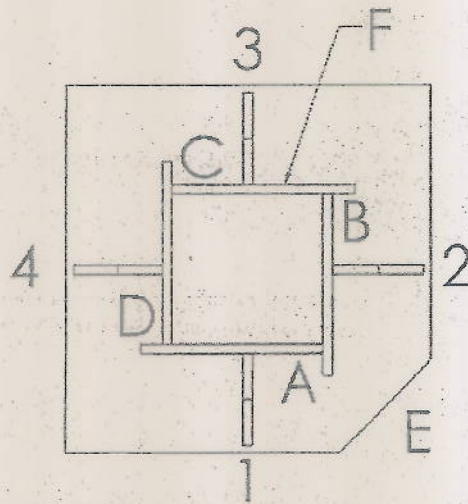

P

GMAW

CONTEST NUMBER 1099

GUSSET		
1	VERTICAL UP	4.5 /5
	VERTICAL DOWN	5 /5
2	VERTICAL UP	4.5 /5
	VERTICAL DOWN	5 /5
3	VERTICAL UP	4.5 /5
	VERTICAL DOWN	5 /5
4	VERTICAL UP	4.5 /5
	VERTICAL DOWN	5 /5
SIDE		
A	VERTICAL UP	8.5 /10
B	VERTICAL DOWN	9.5 /10
C	VERTICAL UP	8.5 /10
D	VERTICAL DOWN	9.5 /10
PAC		
E	PLASMA CUT	9 /10
ALL AROUND		
F	BASEPLATE WELD	7 /10
LAYOUT PENALTY		-
90		/100 PTS

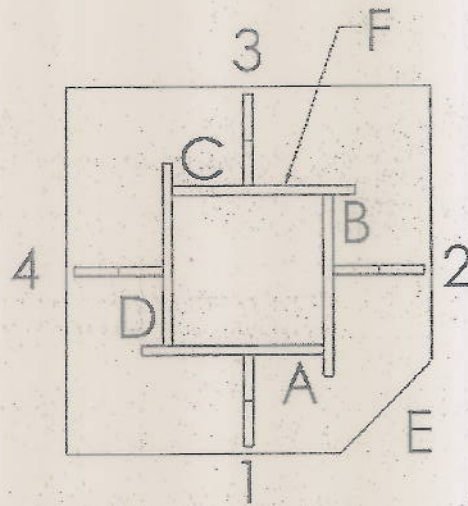

Vertical ups are very consistent!
 And your vert-downs
 are fantastic!
 Base-plate welds are a little
 cold & shakyy, but
 overall, great job!

B

GMAW

CONTEST NUMBER 1123

GUSSET			
1	VERTICAL UP	3	/5
	VERTICAL DOWN	3	/5
2	VERTICAL UP	2.5	/5
	VERTICAL DOWN	3	/5
3	VERTICAL UP	2.5	/5
	VERTICAL DOWN	3	/5
4	VERTICAL UP	2.5	/5
	VERTICAL DOWN	3	/5
SIDE		22.5	
A	VERTICAL UP	6	/10
B	VERTICAL DOWN	7	/10
C	VERTICAL UP	6	/10
D	VERTICAL DOWN	7	/10
PAC		26	
E	PLASMA CUT	8	/10
ALL AROUND			
F	BASEPLATE WELD	6.44	/10
LAYOUT PENALTY		4	
		58.5	/100 PTS

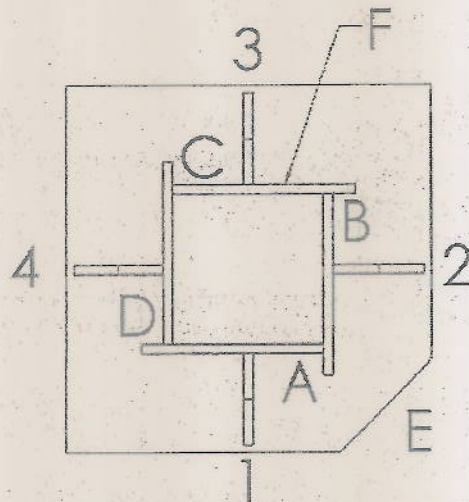

A/B/C/D vertical welds
are not to print
issues with welds on the
base plate

A

GMAW

CONTEST NUMBER 1145

GUSSET		
1	VERTICAL UP	2.5 /5
	VERTICAL DOWN	4.5 /5
2	VERTICAL UP	2.5 /5
	VERTICAL DOWN	4 /5
3	VERTICAL UP	2.5 /5
	VERTICAL DOWN	3.5 /5
4	VERTICAL UP	2.5 /5
	VERTICAL DOWN	4 /5
SIDE		26
A	VERTICAL UP	6 /10
B	VERTICAL DOWN	0 /10
C	VERTICAL UP	5.5 /10
D	VERTICAL DOWN	8.0 /10
PAC		19.5
E	PLASMA CUT	8 /10
ALL AROUND		
F	BASEPLATE WELD	6 /10
LAYOUT PENALTY		3
		56.5 /100 PTS

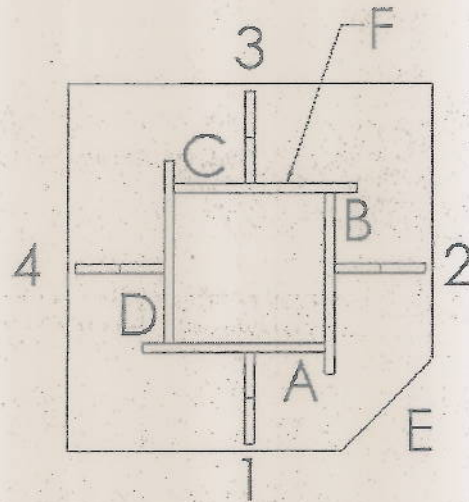

- great Plasma cut!
 Size is too big.
 - lack of fusion on base-plates.

P

GMAW

CONTEST NUMBER 1162

GUSSET			
1	VERTICAL UP	0	/5
	VERTICAL DOWN	0	/5
2	VERTICAL UP	2.5	/5
	VERTICAL DOWN	2.5	/5
3	VERTICAL UP	2.5	/5
	VERTICAL DOWN	2.5	/5
4	VERTICAL UP	2.5	/5
	VERTICAL DOWN	2.5	/5
SIDE		15	
A	VERTICAL UP	3	/10
B	VERTICAL DOWN	3	/10
C	VERTICAL UP	3	/10
D	VERTICAL DOWN	3	/10
PAC		12	
E	PLASMA CUT	0	/10
ALL AROUND			
F	BASEPLATE WELD	0 ₂₇	/10
LAYOUT PENALTY		10	-
		17	/100 PTS

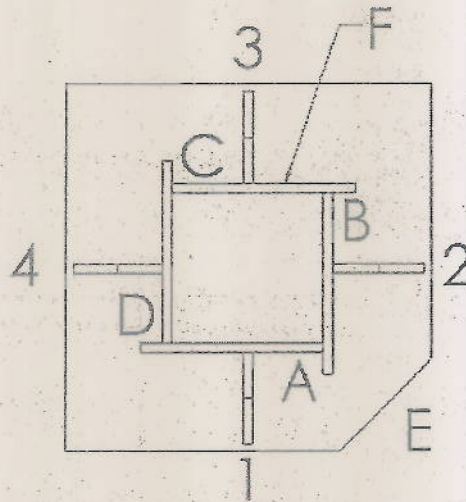

Overall layout is incorrect
 good attempt!
 give yourself more time
 next time!

A

GMAW

CONTEST NUMBER 1164

GUSSET		
1	VERTICAL UP	3.5 /5
	VERTICAL DOWN	4 /5
2	VERTICAL UP	3.5 /5
	VERTICAL DOWN	4 /5
3	VERTICAL UP	3 /5
	VERTICAL DOWN	4 /5
4	VERTICAL UP	3.5 /5
	VERTICAL DOWN	4 /5
SIDE		29.5
A	VERTICAL UP	7.5 /10
B	VERTICAL DOWN	8.5 /10
C	VERTICAL UP	7.5 /10
D	VERTICAL DOWN	8.5 /10
PAC		32
E	PLASMA CUT	8 /10
ALL AROUND		
F	BASEPLATE WELD	8.5 /10 16.5
LAYOUT PENALTY		-
78		/100 PTS

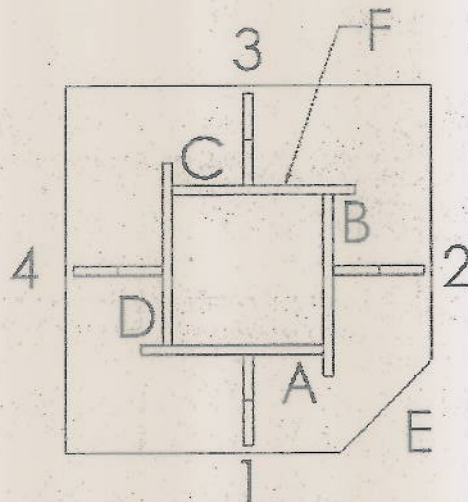

Baseplate welds look nice & consistent! Nice job overall

GMAW

CONTEST NUMBER 1168

GUSSET		
1	VERTICAL UP	2.5 /5
	VERTICAL DOWN	2 /5
2	VERTICAL UP	0 /5
	VERTICAL DOWN	0 /5
3	VERTICAL UP	0 /5
	VERTICAL DOWN	0 /5
4	VERTICAL UP	2 /5
	VERTICAL DOWN	2 /5
SIDE		8.5
A	VERTICAL UP	0 /10
B	VERTICAL DOWN	0 /10
C	VERTICAL UP	7 /10
D	VERTICAL DOWN	6 /10
PAC		13
E	PLASMA CUT	0 /10
ALL AROUND		
F	BASEPLATE WELD	0 /10
LAYOUT PENALTY		5
		11.5 /100 PTS

> these welds are backwards to print

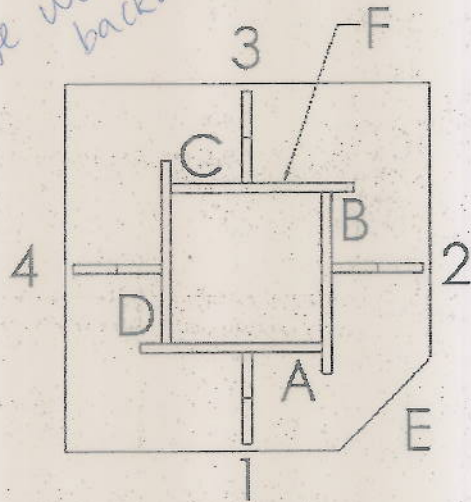

layout is off, missing welds, but good attempt! Better luck next year!

GMAW

CONTEST NUMBER 1173

GUSSET		
1	VERTICAL UP	3.5 /5
	VERTICAL DOWN	3.5 /5
2	VERTICAL UP	3.5 /5
	VERTICAL DOWN	3.5 /5
3	VERTICAL UP	3.5 /5
	VERTICAL DOWN	3.5 /5
4	VERTICAL UP	3.5 /5
	VERTICAL DOWN	3.5 /5
SIDE		
A	VERTICAL UP	6.5 /10
B	VERTICAL DOWN	7 /10
C	VERTICAL UP	6 /10
D	VERTICAL DOWN	7 /10
PAC		
E	PLASMA CUT	7.5 /10
ALL AROUND		
F	BASEPLATE WELD	7.5 /10
LAYOUT PENALTY		2
67.5		/100 PTS

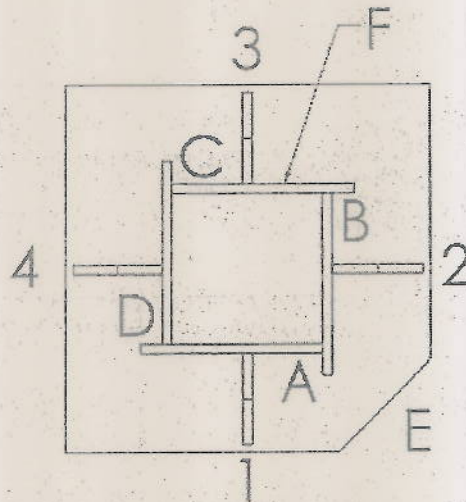

A

GMAW

CONTEST NUMBER 1174

GUSSET		
1	VERTICAL UP	2.5 /5
	VERTICAL DOWN	2.5 /5
2	VERTICAL UP	2 /5
	VERTICAL DOWN	2.5 /5
3	VERTICAL UP	2 /5
	VERTICAL DOWN	2.5 /5
4	VERTICAL UP	2 /5
	VERTICAL DOWN	2.5 /5
SIDE		
A	VERTICAL UP	4 /10
B	VERTICAL DOWN	5.5 /10
C	VERTICAL UP	4 /10
D	VERTICAL DOWN	5.5 /10
PAC		
E	PLASMA CUT	5 /10
ALL AROUND		
F	BASEPLATE WELD	0 /10
LAYOUT PENALTY		5
37.5 /100 PTS		

18.5

19

5

42.5
-5
37.5

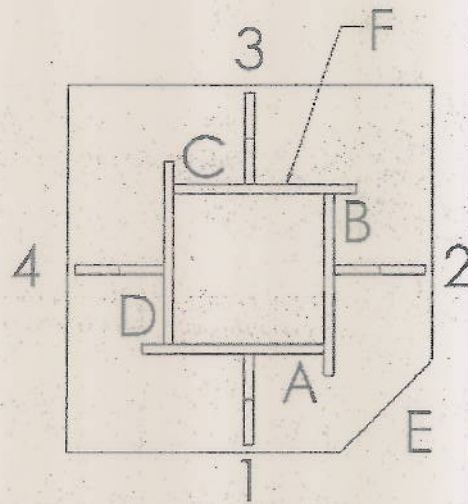

MCD

P

GMAW

CONTEST NUMBER 1175

GUSSET		
1	VERTICAL UP	3 /5
	VERTICAL DOWN	2.5 /5
2	VERTICAL UP	3 /5
	VERTICAL DOWN	3 /5
3	VERTICAL UP	3 /5
	VERTICAL DOWN	3 /5
4	VERTICAL UP	2.5 /5
	VERTICAL DOWN	3 /5
SIDE		
A	VERTICAL UP	6 /10
B	VERTICAL DOWN	7 /10
C	VERTICAL UP	6.5 /10
D	VERTICAL DOWN	6 /10
PAC		
E	PLASMA CUT	5 /10
ALL AROUND		
F	BASEPLATE WELD	6 /10
LAYOUT PENALTY		6
53.5		/100 PTS

> welds look backwards than what's called out on print

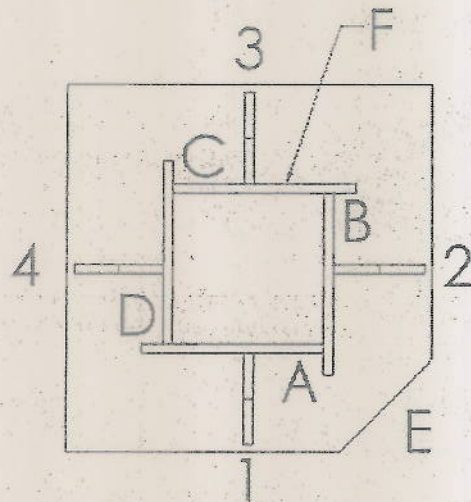

layout not to print, gussets are crooked & broken tacks left sharp edges overall, not bad!

A

GMAW

CONTEST NUMBER 1180

GUSSET		
1	VERTICAL UP	5 /5
	VERTICAL DOWN	5 /5
2	VERTICAL UP	5 /5
	VERTICAL DOWN	5 /5
3	VERTICAL UP	5 /5
	VERTICAL DOWN	5 /5
4	VERTICAL UP	5 /5
	VERTICAL DOWN	5 /5
SIDE		
A	VERTICAL UP	8 /10
B	VERTICAL DOWN	8 /10
C	VERTICAL UP	8 /10
D	VERTICAL DOWN	8 /10
PAC		
E	PLASMA CUT	8 /10
ALL AROUND		
F	BASEPLATE WELD	8 /10
LAYOUT PENALTY		-
88 /100 PTS		

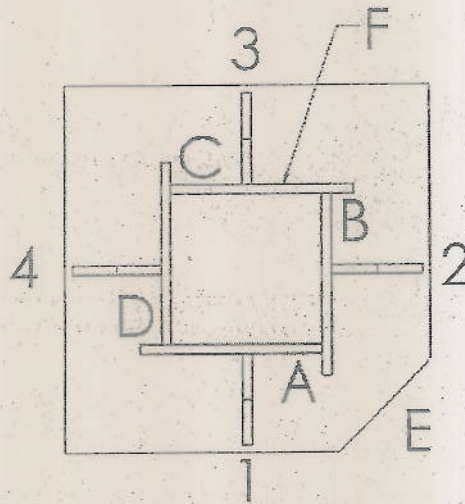

Nice Consistent good Vert-UPS!
Job!

88 MJD

AJ

GMAW

CONTEST NUMBER 1187

GUSSET		
1	VERTICAL UP	0 /5
	VERTICAL DOWN	5 /5
2	VERTICAL UP	4 /5
	VERTICAL DOWN	5 /5
3	VERTICAL UP	4.5 /5
	VERTICAL DOWN	4.5 /5
4	VERTICAL UP	4 /5
	VERTICAL DOWN	5 /5
SIDE		32
A	VERTICAL UP	9 /10
B	VERTICAL DOWN	8.5 /10
C	VERTICAL UP	9.5 /10
D	VERTICAL DOWN	8 /10
PAC		
E	PLASMA CUT	7 /10
ALL AROUND		
F	BASEPLATE WELD	6.5 /10
LAYOUT PENALTY		-
		80.5 /100 PTS

- missing this weld

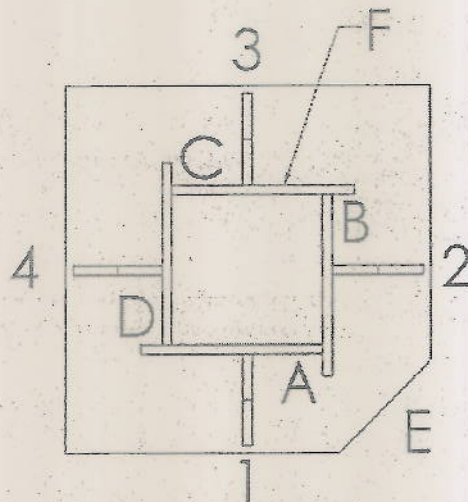

Some of the welds are missing,
there are some really
nice welds here!
good job!

A

GMAW

CONTEST NUMBER 1197

GUSSET		
1	VERTICAL UP	2.5 /5
	VERTICAL DOWN	4 /5
2	VERTICAL UP	2.5 /5
	VERTICAL DOWN	4 /5
3	VERTICAL UP	3.5 /5
	VERTICAL DOWN	4 /5
4	VERTICAL UP	2.5 /5
	VERTICAL DOWN	4 /5
SIDE		
A	VERTICAL UP	3 /10
B	VERTICAL DOWN	8.5 /10
C	VERTICAL UP	3 /10
D	VERTICAL DOWN	8.5 /10
PAC		
E	PLASMA CUT	7.5 /10
ALL AROUND		
F	BASEPLATE WELD	7.5 /10
LAYOUT PENALTY		-
		65 /100 PTS

27

23

15
65
- 0
65

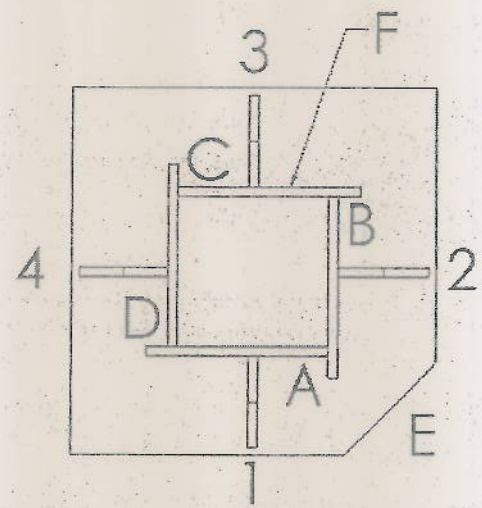

layout is really nice!
vert-downs are nice & consistent!

P

GMAW

CONTEST NUMBER 1343

GUSSET		
1	VERTICAL UP	4.5 /5
	VERTICAL DOWN	4.5 /5
2	VERTICAL UP	4.5 /5
	VERTICAL DOWN	4.5 /5
3	VERTICAL UP	4.5 /5
	VERTICAL DOWN	4.5 /5
4	VERTICAL UP	4.5 /5
	VERTICAL DOWN	4.5 /5
SIDE		36
A	VERTICAL UP	8.5 /10
B	VERTICAL DOWN	7 /10
C	VERTICAL UP	8 /10
D	VERTICAL DOWN	7 /10
PAC		30.5
E	PLASMA CUT	8.5 /10
ALL AROUND		
F	BASEPLATE WELD	8 /10
LAYOUT PENALTY		3
		80 /100 PTS

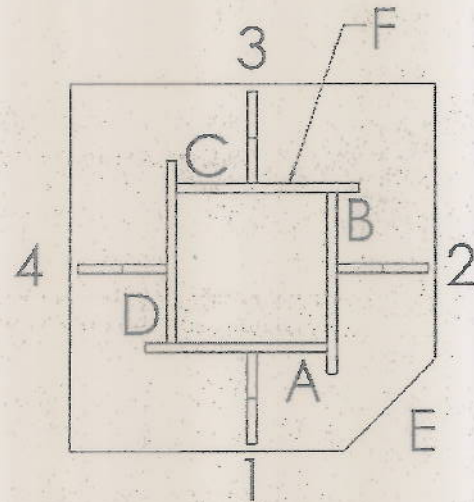

>16.5 A/B/C/D weld placements
 not to print
 overall, good job

A ✓

GMAW

CONTEST NUMBER 1352

GUSSET		
1	VERTICAL UP	2.5 /5
	VERTICAL DOWN	3 /5
2	VERTICAL UP	2 /5
	VERTICAL DOWN	3.5 /5
3	VERTICAL UP	2.5 /5
	VERTICAL DOWN	3.5 /5
4	VERTICAL UP	3 /5
	VERTICAL DOWN	3.5 /5
SIDE		23.5
A	VERTICAL UP	6 /10
B	VERTICAL DOWN	5.5 /10
C	VERTICAL UP	6 /10
D	VERTICAL DOWN	5.5 /10
PAC		
E	PLASMA CUT	7.5 /10
ALL AROUND		
F	BASEPLATE WELD	6.5 /10
LAYOUT PENALTY		-
60.5		/100 PTS

Weld locations are all backwards

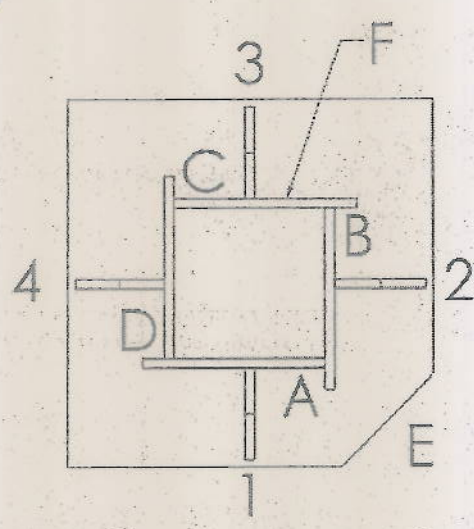

layout is really nice!

P ✓

GMAW

CONTEST NUMBER 1357

GUSSET		
1	VERTICAL UP	1 /5
	VERTICAL DOWN	2.5 /5
2	VERTICAL UP	1 /5
	VERTICAL DOWN	1 /5
3	VERTICAL UP	1 /5
	VERTICAL DOWN	1.5 /5
4	VERTICAL UP	1 /5
	VERTICAL DOWN	1 /5
SIDE		10
A	VERTICAL UP	3.5 /10
B	VERTICAL DOWN	4.5 /10
C	VERTICAL UP	2.5 /10
D	VERTICAL DOWN	4.5 /10
PAC		15
E	PLASMA CUT	8 /10
ALL AROUND		
F	BASEPLATE WELD	3 /10
LAYOUT PENALTY		5 -
31		/100 PTS

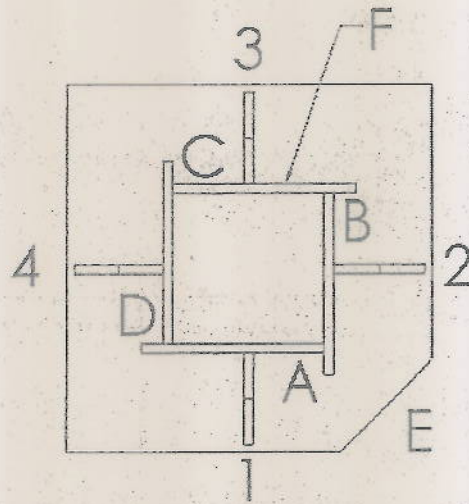

nice Plasma cut!

211

2

GMAW

CONTEST NUMBER 1358

GUSSET		
1	VERTICAL UP	0 /5
	VERTICAL DOWN	0 /5
2	VERTICAL UP	0 /5
	VERTICAL DOWN	0 /5
3	VERTICAL UP	0 /5
	VERTICAL DOWN	0 /5
4	VERTICAL UP	0 /5
	VERTICAL DOWN	0 /5
SIDE		
A	VERTICAL UP	0 /10
B	VERTICAL DOWN	0 /10
C	VERTICAL UP	0 /10
D	VERTICAL DOWN	0 /10
PAC		
E	PLASMA CUT	5 /10
ALL AROUND		
F	BASEPLATE WELD	0 /10
LAYOUT PENALTY		-
5		/100 PTS

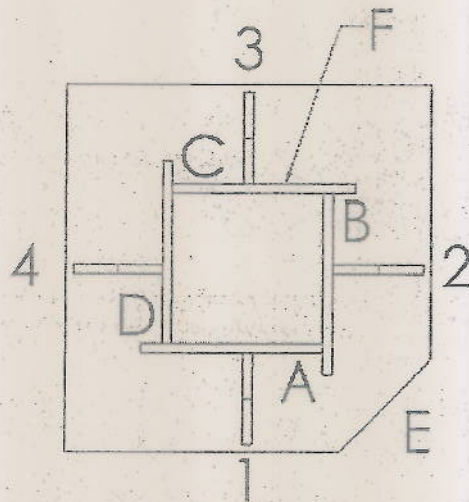

P

GMAW

CONTEST NUMBER 1409

GUSSET		
1	VERTICAL UP	2.5 /5
	VERTICAL DOWN	2.5 /5
2	VERTICAL UP	2.5 /5
	VERTICAL DOWN	2.5 /5
3	VERTICAL UP	2.5 /5
	VERTICAL DOWN	2.5 /5
4	VERTICAL UP	2.5 /5
	VERTICAL DOWN	2.5 /5
SIDE		20
A	VERTICAL UP	5 /10
B	VERTICAL DOWN	5 /10
C	VERTICAL UP	5 /10
D	VERTICAL DOWN	5 /10
PAC		20
E	PLASMA CUT	7 /10
ALL AROUND		
F	BASEPLATE WELD	6.5 /10
LAYOUT PENALTY		5
48.5		/100 PTS

Weld locations are all backwards

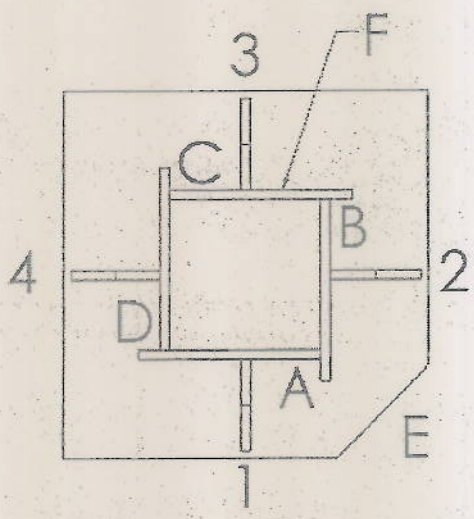

Overall layout is off, makes the weld locations incorrect.

GMAW

CONTEST NUMBER

1426

GUSSET		
1	VERTICAL UP	2.5 /5
	VERTICAL DOWN	3.5 /5
2	VERTICAL UP	2.5 /5
	VERTICAL DOWN	3.5 /5
3	VERTICAL UP	2.5 /5
	VERTICAL DOWN	3.5 /5
4	VERTICAL UP	2.5 /5
	VERTICAL DOWN	3.5 /5
SIDE		24
A	VERTICAL UP	6 /10
B	VERTICAL DOWN	7.5 /10
C	VERTICAL UP	6 /10
D	VERTICAL DOWN	7 /10
PAC		26.5
E	PLASMA CUT	0 /10
ALL AROUND		
F	BASEPLATE WELD	8 /10
LAYOUT PENALTY		6
		52.5 /100 PTS

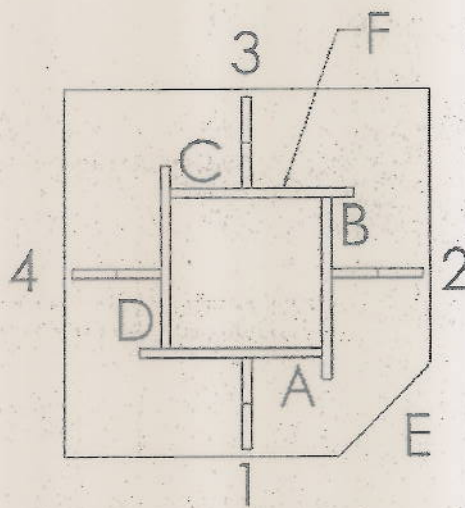

Missing the plasma cut
 & the whole assembly is
 twisted. Baseplate welds
 look good!

A

GMAW

CONTEST NUMBER 1442

GUSSET			
1	VERTICAL UP	3	/5
	VERTICAL DOWN	4	/5
2	VERTICAL UP	3	/5
	VERTICAL DOWN	4	/5
3	VERTICAL UP	2.5	/5
	VERTICAL DOWN	4	/5
4	VERTICAL UP	3	/5
	VERTICAL DOWN	4.5	/5
SIDE		29	
A	VERTICAL UP	6	/10
B	VERTICAL DOWN	8.5	/10
C	VERTICAL UP	6.5	/10
D	VERTICAL DOWN	8.5	/10
PAC			
E	PLASMA CUT	7.5	/10
ALL AROUND			
F	BASEPLATE WELD	7.5	/10
LAYOUT PENALTY		3	
		69.5	/100 PTS

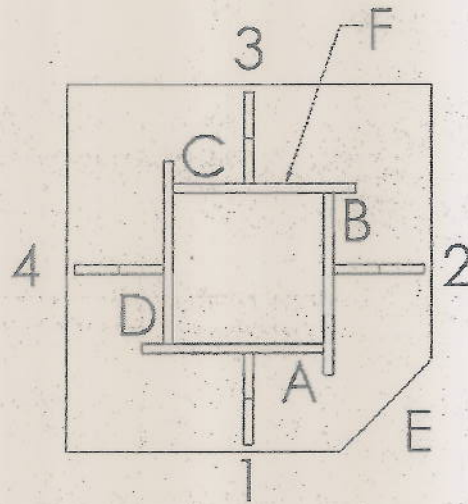

layout is a little off,
but nice job on the
vert-downs!

P

GMAW

CONTEST NUMBER 14165

GUSSET		
1	VERTICAL UP	1.5 /5
	VERTICAL DOWN	2.5 /5
2	VERTICAL UP	1.5 /5
	VERTICAL DOWN	1 /5
3	VERTICAL UP	1.5 /5
	VERTICAL DOWN	2 /5
4	VERTICAL UP	1.5 /5
	VERTICAL DOWN	2 /5
SIDE		
A	VERTICAL UP	3.5 /10
B	VERTICAL DOWN	4 /10
C	VERTICAL UP	3 /10
D	VERTICAL DOWN	4 /10
PAC		
E	PLASMA CUT	6.5 /10
ALL AROUND		
F	BASEPLATE WELD	3 /10
LAYOUT PENALTY		5
35.5		/100 PTS

13.5

14.5

9.5

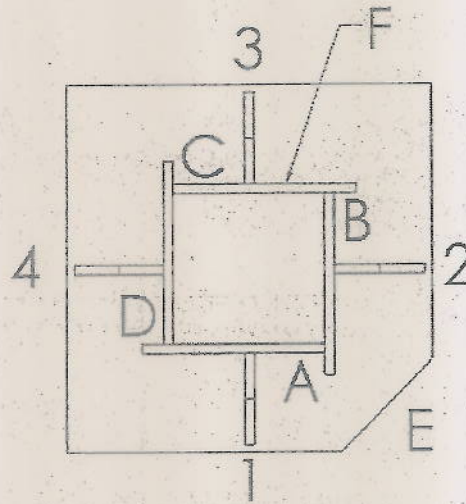

P ✓

GMAW

CONTEST NUMBER

1499

GUSSET			
1	VERTICAL UP	1	/5
	VERTICAL DOWN	3	/5
2	VERTICAL UP	2	/5
	VERTICAL DOWN	2.5	/5
3	VERTICAL UP	1	/5
	VERTICAL DOWN	2.5	/5
4	VERTICAL UP	1	/5
	VERTICAL DOWN	2.5	/5
SIDE		15.5	
A	VERTICAL UP	4	/10
B	VERTICAL DOWN	8	/10
C	VERTICAL UP	4	/10
D	VERTICAL DOWN	8	/10
PAC		24	
E	PLASMA CUT	4	/10
ALL AROUND			
F	BASEPLATE WELD	6.5	/10
LAYOUT PENALTY		5	
45		/100 PTS	

welds are backwards

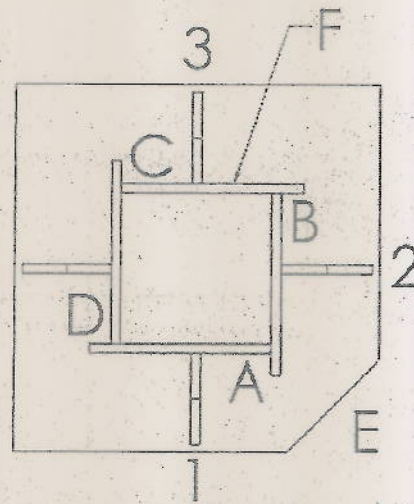

nice vert-downs!

10.5

45.0K

P

GMAW

CONTEST NUMBER 1503

GUSSET		
1	VERTICAL UP	2.5 /5
	VERTICAL DOWN	2.5 /5
2	VERTICAL UP	2.5 /5
	VERTICAL DOWN	2.5 /5
3	VERTICAL UP	2.5 /5
	VERTICAL DOWN	2.5 /5
4	VERTICAL UP	2.5 /5
	VERTICAL DOWN	2.5 /5
SIDE		20
A	VERTICAL UP	7 /10
B	VERTICAL DOWN	7 /10
C	VERTICAL UP	6.5 /10
D	VERTICAL DOWN	4.5 /10
PAC		
E	PLASMA CUT	6.5 /10
ALL AROUND		
F	BASEPLATE WELD	6.5 /10
LAYOUT PENALTY		3
55		/100 PTS

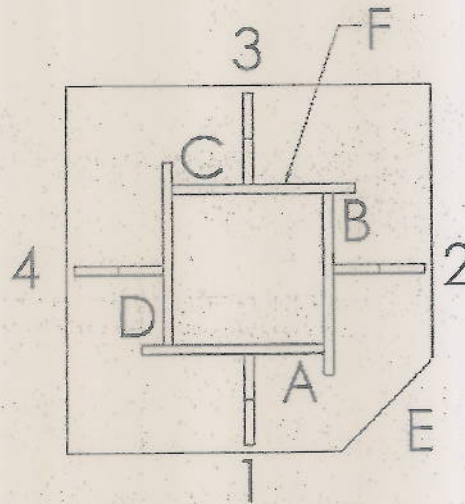

25

13

P

GMAW

CONTEST NUMBER 1509

GUSSET		
1	VERTICAL UP	2.5 /5
	VERTICAL DOWN	4 /5
2	VERTICAL UP	2.5 /5
	VERTICAL DOWN	4 /5
3	VERTICAL UP	2 /5
	VERTICAL DOWN	4 /5
4	VERTICAL UP	2.5 /5
	VERTICAL DOWN	4 /5
SIDE		25.5
A	VERTICAL UP	6 /10
B	VERTICAL DOWN	8 /10
C	VERTICAL UP	6 /10
D	VERTICAL DOWN	8 /10
PAC		28
E	PLASMA CUT	7 /10
ALL AROUND		
F	BASEPLATE WELD	7 /10
LAYOUT PENALTY		0.5
67		/100 PTS

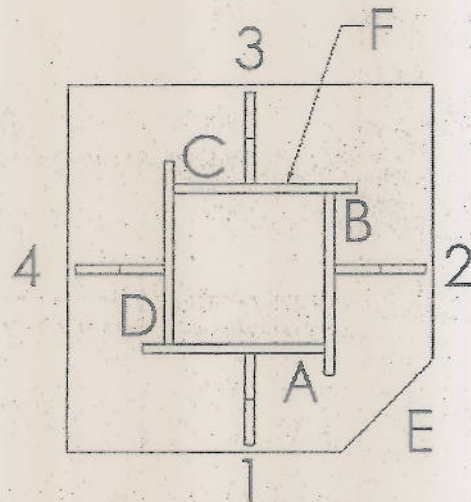

*layout is pretty good!
 some gussets are
 a little cracked,
 but overall, good job!*

P

GMAW

CONTEST NUMBER 1528

GUSSET		
1	VERTICAL UP	2.5 /5
	VERTICAL DOWN	3.5 /5
2	VERTICAL UP	2.5 /5
	VERTICAL DOWN	3 /5
3	VERTICAL UP	2 /5
	VERTICAL DOWN	3 /5
4	VERTICAL UP	2 /5
	VERTICAL DOWN	2.5 /5
SIDE		21
A	VERTICAL UP	5 /10
B	VERTICAL DOWN	7 /10
C	VERTICAL UP	5 /10
D	VERTICAL DOWN	0 /10
PAC		17
E	PLASMA CUT	5 /10
ALL AROUND		
F	BASEPLATE WELD	5 /10
LAYOUT PENALTY		4
44		/100 PTS

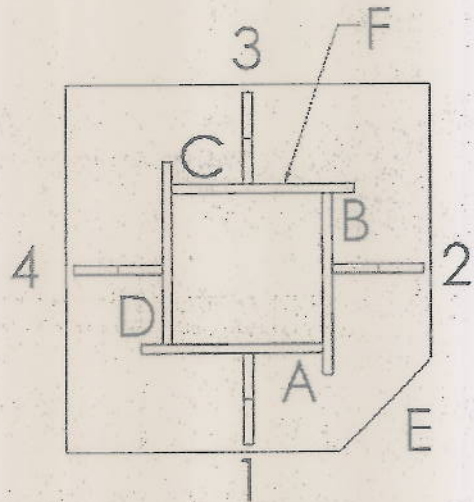

lack of fusion on most welds, Plasma cut is long, and missing some welds.

GMAW

CONTEST NUMBER 1537

GUSSET		
1	VERTICAL UP	/5
	VERTICAL DOWN	/5
2	VERTICAL UP	/5
	VERTICAL DOWN	/5
3	VERTICAL UP	/5
	VERTICAL DOWN	/5
4	VERTICAL UP	/5
	VERTICAL DOWN	/5
SIDE		
A	VERTICAL UP	/10
B	VERTICAL DOWN	/10
C	VERTICAL UP	/10
D	VERTICAL DOWN	/10
PAC		
E	PLASMA CUT	/10
ALL AROUND		
F	BASEPLATE WELD	/10
LAYOUT PENALTY		-
<u>0</u>		/100 PTS

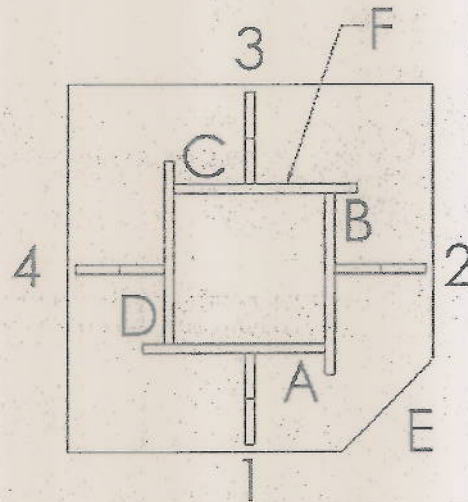

*Nothing to judge,
try to give us
something next
time 😊*

A

GMAW

CONTEST NUMBER 1545

GUSSET		
1	VERTICAL UP	3 /5
	VERTICAL DOWN	4 /5
2	VERTICAL UP	3 /5
	VERTICAL DOWN	4 /5
3	VERTICAL UP	3 /5
	VERTICAL DOWN	3.5 /5
4	VERTICAL UP	3 /5
	VERTICAL DOWN	4 /5
SIDE		27.5
A	VERTICAL UP	7.5 /10
B	VERTICAL DOWN	8 /10
C	VERTICAL UP	7.5 /10
D	VERTICAL DOWN	8 /10
PAC		
E	PLASMA CUT	8.5 /10
ALL AROUND		
F	BASEPLATE WELD	8.5 /10
LAYOUT PENALTY		-
		75.5 /100 PTS

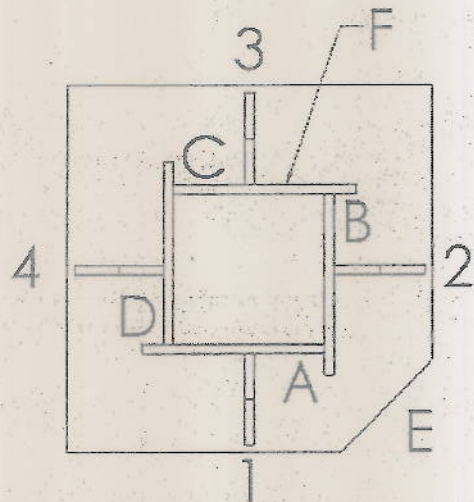

layout is Spot on
great job on that!

Nice consistent welds!
Overall, good job!

A

GMAW

CONTEST NUMBER 1553

GUSSET		
1	VERTICAL UP	2 /5
	VERTICAL DOWN	4 /5
2	VERTICAL UP	2 /5
	VERTICAL DOWN	3.5 /5
3	VERTICAL UP	1.5 /5
	VERTICAL DOWN	3 /5
4	VERTICAL UP	2 /5
	VERTICAL DOWN	3.5 /5
SIDE		21.5
A	VERTICAL UP	3.5 /10
B	VERTICAL DOWN	5 /10
C	VERTICAL UP	3 /10
D	VERTICAL DOWN	5 /10
PAC		16.5
E	PLASMA CUT	7 /10
ALL AROUND		
F	BASEPLATE WELD	6 /10 13
LAYOUT PENALTY		5
46		/100 PTS

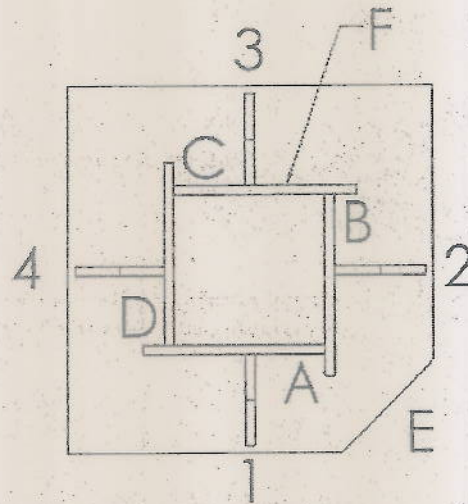

P ✓

GMAW

CONTEST NUMBER 1559

GUSSET			
1	VERTICAL UP	3.5	/5
	VERTICAL DOWN	4	/5
2	VERTICAL UP	3.5	/5
	VERTICAL DOWN	4	/5
3	VERTICAL UP	3.5	/5
	VERTICAL DOWN	4	/5
4	VERTICAL UP	3.5	/5
	VERTICAL DOWN	4	/5
SIDE		30	
A	VERTICAL UP	7.5	/10
B	VERTICAL DOWN	8	/10
C	VERTICAL UP	7.5	/10
D	VERTICAL DOWN	8	/10
PAC		15+10	
E	PLASMA CUT	7.5	/10
ALL AROUND			
F	BASEPLATE WELD	7.5	/10
LAYOUT PENALTY			-
		74	/100 PTS

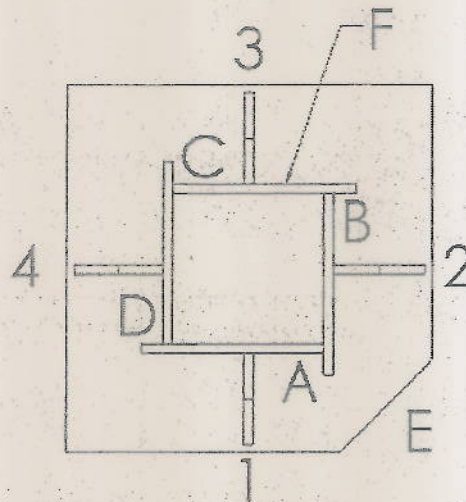

Watch plasma cut angle
Vertical downs pretty consistent

A

GMAW

CONTEST NUMBER 1560

GUSSET		
1	VERTICAL UP	2 /5
	VERTICAL DOWN	2.5 /5
2	VERTICAL UP	2 /5
	VERTICAL DOWN	2.5 /5
3	VERTICAL UP	2.5 /5
	VERTICAL DOWN	2.5 /5
4	VERTICAL UP	2.5 /5
	VERTICAL DOWN	2.5 /5
SIDE		19
A	VERTICAL UP	6 /10
B	VERTICAL DOWN	6.5 /10
C	VERTICAL UP	6 /10
D	VERTICAL DOWN	6 /10
PAC		24.5
E	PLASMA CUT	7.5 /10
ALL AROUND		
F	BASEPLATE WELD	5.5 /10
LAYOUT PENALTY		3
		53.5 /100 PTS

All gusset welds look to be vert-ups - not to print.

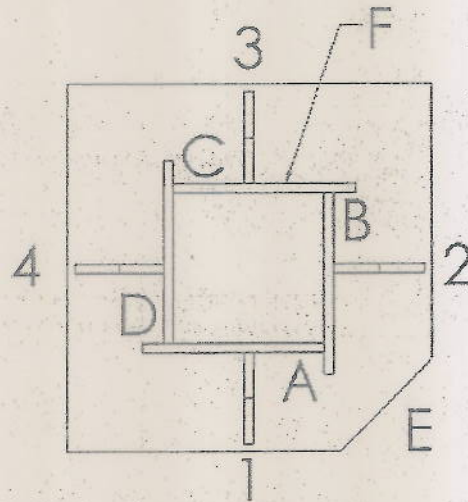

- a little Shaky, but a good quality cut!
Baseplate welds not wrapped on the edges, the layout measurements look good!

A

GMAW

CONTEST NUMBER 1735

GUSSET		
1	VERTICAL UP	3.5 /5
	VERTICAL DOWN	8.5 /5
2	VERTICAL UP	3.5 /5
	VERTICAL DOWN	4.5 /5
3	VERTICAL UP	3.5 /5
	VERTICAL DOWN	4 /5
4	VERTICAL UP	3.5 /5
	VERTICAL DOWN	4 /5
SIDE		31.5
A	VERTICAL UP	8 /10
B	VERTICAL DOWN	8.5 /10
C	VERTICAL UP	8 /10
D	VERTICAL DOWN	8.5 /10
PAC		33
E	PLASMA CUT	7.5 /10
ALL AROUND		
F	BASEPLATE WELD	7.5 /10
LAYOUT PENALTY		3
76.5		/100 PTS

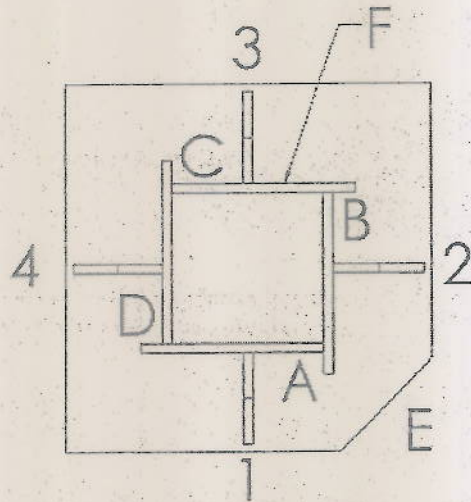

Layout is a bit off, but good job on your verticals!

P ✓

GMAW

CONTEST NUMBER 1750

GUSSET		
1	VERTICAL UP	4.5 /5
	VERTICAL DOWN	4.5 /5
2	VERTICAL UP	4 /5
	VERTICAL DOWN	4.5 /5
3	VERTICAL UP	4 /5
	VERTICAL DOWN	4.5 /5
4	VERTICAL UP	4 /5
	VERTICAL DOWN	4.5 /5
SIDE		34.5
A	VERTICAL UP	8.5 /10
B	VERTICAL DOWN	8.5 /10
C	VERTICAL UP	8 /10
D	VERTICAL DOWN	9 /10
PAC		34
E	PLASMA CUT	7 /10
ALL AROUND		
F	BASEPLATE WELD	9 /10
LAYOUT PENALTY		16
84.5		/100 PTS

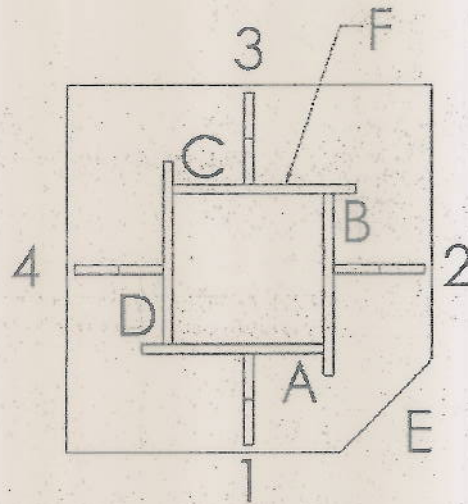

Nice, consistent welds!

P

GMAW

CONTEST NUMBER 1989

GUSSET		
1	VERTICAL UP	2 /5
	VERTICAL DOWN	2.5 /5
2	VERTICAL UP	2 /5
	VERTICAL DOWN	3 /5
3	VERTICAL UP	2 /5
	VERTICAL DOWN	2.5 /5
4	VERTICAL UP	2 /5
	VERTICAL DOWN	2.5 /5
SIDE		18.5
A	VERTICAL UP	4.5 /10
B	VERTICAL DOWN	5 /10
C	VERTICAL UP	5 /10
D	VERTICAL DOWN	6 /10
PAC		20.5
E	PLASMA CUT	6.5 /10
ALL AROUND		
F	BASEPLATE WELD	7 /10
LAYOUT PENALTY		3
49.5		/100 PTS

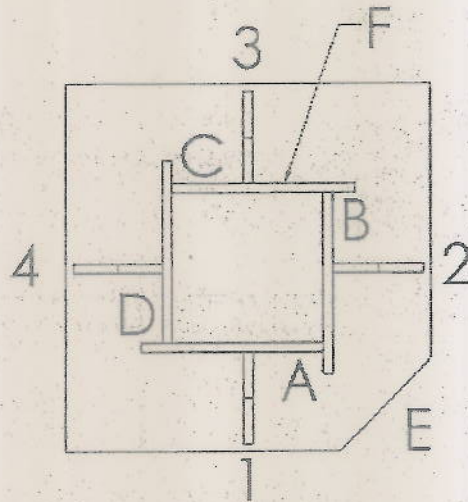

Layout is a little off, nice consistent base plate welds

P

GMAW

CONTEST NUMBER 1990

GUSSET		
1	VERTICAL UP	3 /5
	VERTICAL DOWN	3 /5
2	VERTICAL UP	2.5 /5
	VERTICAL DOWN	3 /5
3	VERTICAL UP	2 /5
	VERTICAL DOWN	3.5 /5
4	VERTICAL UP	2 /5
	VERTICAL DOWN	3.5 /5
SIDE		22.5
A	VERTICAL UP	4 /10
B	VERTICAL DOWN	6 /10
C	VERTICAL UP	4 /10
D	VERTICAL DOWN	6.5 /10
PAC		20.5
E	PLASMA CUT	7 /10
ALL AROUND		
F	BASEPLATE WELD	7 /10
LAYOUT PENALTY		2
55		/100 PTS

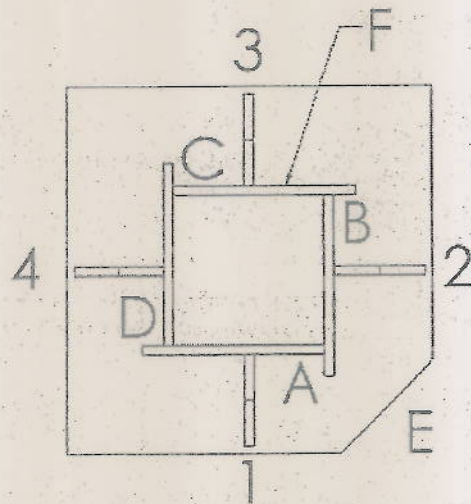

There are some really nice sections of weld on the baseplate!

PJ

GMAW

CONTEST NUMBER 1991

GUSSET		
1	VERTICAL UP	2.5 /5
	VERTICAL DOWN	3 /5
2	VERTICAL UP	2.5 /5
	VERTICAL DOWN	3.5 /5
3	VERTICAL UP	2.5 /5
	VERTICAL DOWN	3 /5
4	VERTICAL UP	2 /5
	VERTICAL DOWN	2.5 /5
SIDE		21.5
A	VERTICAL UP	5.5 /10
B	VERTICAL DOWN	0 /10
C	VERTICAL UP	5.5 /10
D	VERTICAL DOWN	0 /10
PAC		11
E	PLASMA CUT	4 /10
ALL AROUND		
F	BASEPLATE WELD	6 /10
LAYOUT PENALTY		2
40.5		/100 PTS

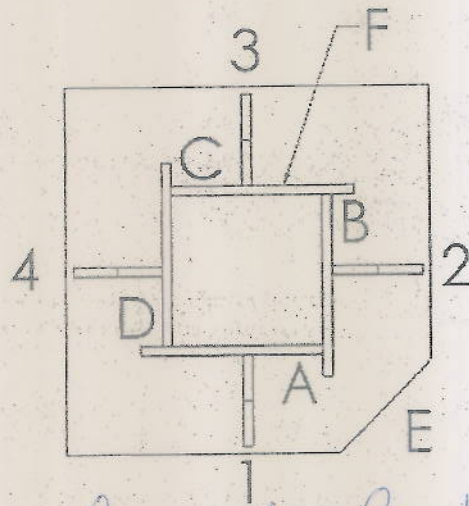

looks to be vert-up weld

10

P ✓

GMAW

CONTEST NUMBER 2065

GUSSET		
1	VERTICAL UP	4 /5
	VERTICAL DOWN	4 /5
2	VERTICAL UP	4.5 /5
	VERTICAL DOWN	4 /5
3	VERTICAL UP	4 /5
	VERTICAL DOWN	4 /5
4	VERTICAL UP	4 /5
	VERTICAL DOWN	4 /5
SIDE		32.5
A	VERTICAL UP	8.5 /10
B	VERTICAL DOWN	7.5 /10
C	VERTICAL UP	8 /10
D	VERTICAL DOWN	7.5 /10
PAC		31.5
E	PLASMA CUT	10 /10
ALL AROUND		
F	BASEPLATE WELD	6.5 /10
LAYOUT PENALTY		-
		80.5 /100 PTS

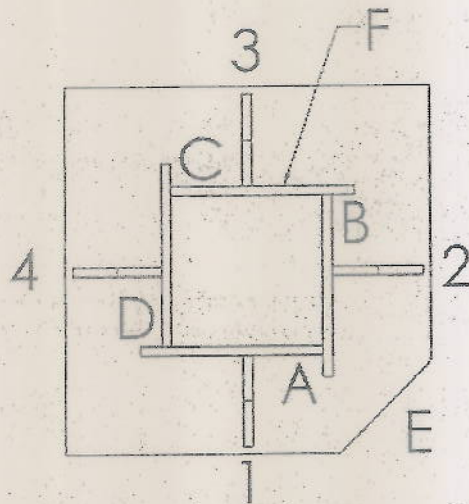

- Very nice plasma cut!
 Baseplate welds are very large,
 tightens up your weave,
 but overall nice job!

B

Rank	Contest #
1	1024
2	1023
3	1048
4	1343
5	1180
6	1750
7	1099
8	1095
9	1042
10	1545
11	1735
12	1559
13	1173
14	1003
15	1197
16	1164
17	2065
18	1097
19	1031
20	1442
21	1352
22	1032
23	1066
24	1175
25	1145
26	1990
27	1991
28	1065
29	1087
30	1560

1st

Jan Uandre
Marshfield

Emerson Young

Nash Sullivan
Wisconsin Rapids